

# Linear Solenoids

## Frame Solenoids – Standard

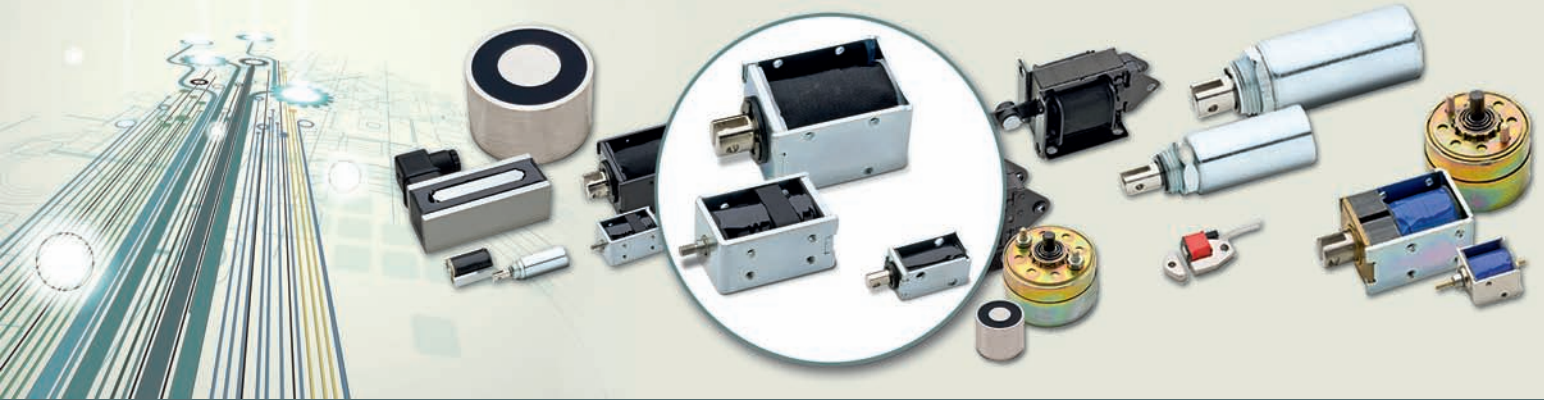

Small Frame / Adequate for Overload / Solid

**STSS-81143**

### Type

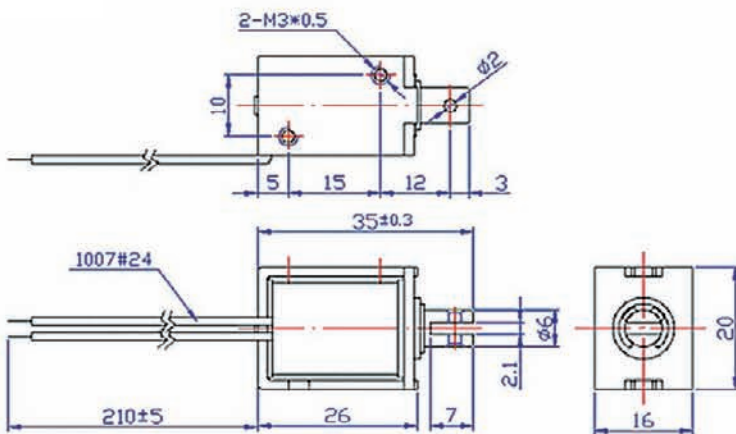

### Force-stroke-diagram (N/mm)

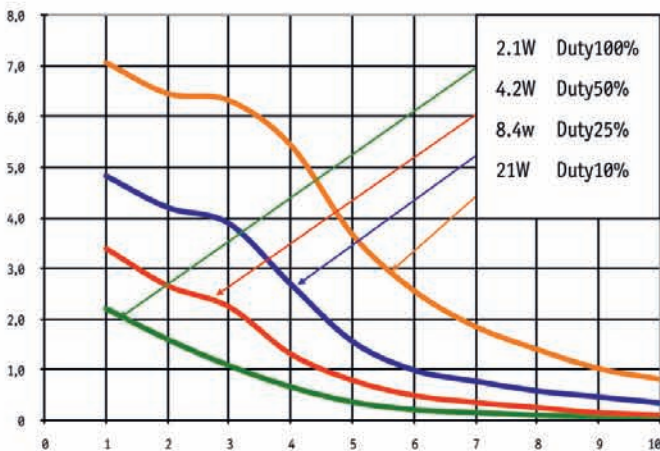

### Description

Cheap and light-weight based on frame mode construction. Including damping ring and dumper inside the case. Open framed solenoid with closed brace.

Small but with overload passably stroke at the 8-11 mm.

Weight: 43 g

### Coil Data

Relative Duty Cycle (%)	100	50	25	10
Max. Performance (Watt)	2,1	4,2	8,4	21
Max. Duty Cycle (sec.)	∞	55	19	3

### Solenoid Model

Version:

Pull magnet

Pressure Solenoid with spring return

Current:

12 VDC (standard)

24 VDC (standard)

Please ask for other options.

### Special Development On Request

Please contact us for your custom designed part (frame, force, special application, etc.)



**SHENG TENG GmbH**  
 VAT-ID: DE 271 696 661  
 General Manager:  
 Silvio Bruske / Frank Loeffler  
 District Court Munich reg. # HRB185777

Angerbrunnenstraße 11  
 D-85356 Freising  
 GERMANY

Phone: +49-8161-986 44 84  
 Fax: +49-8161-986 44 74  
 eMail: office@shengteng.de

[www.shengteng.de](http://www.shengteng.de)