

Linear Solenoids

Frame Solenoids – Standard

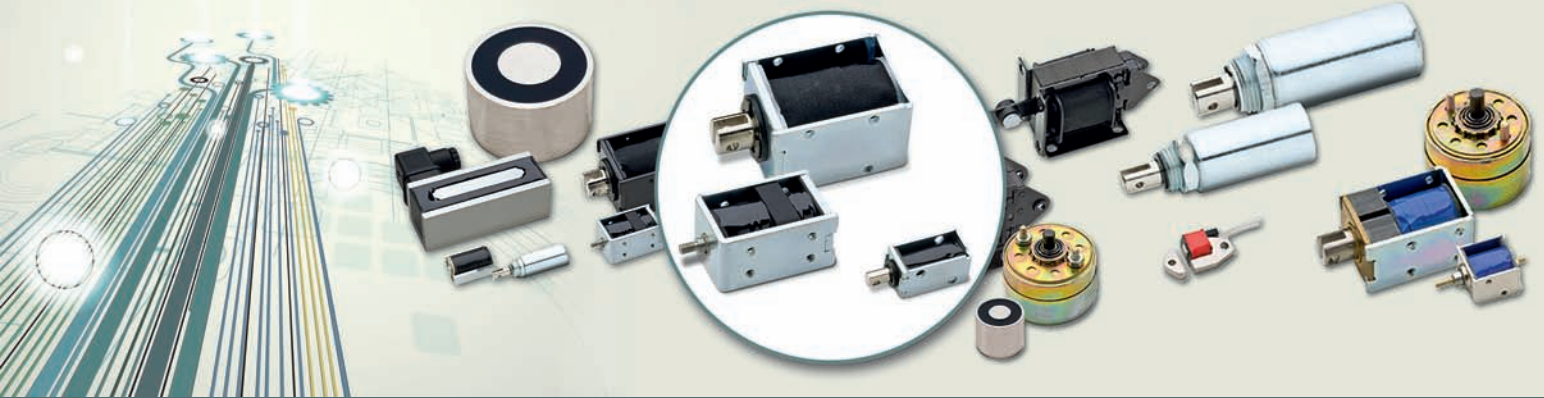

Middle Frame / Adequate for Overload / Solid

STSS-1220147

Type

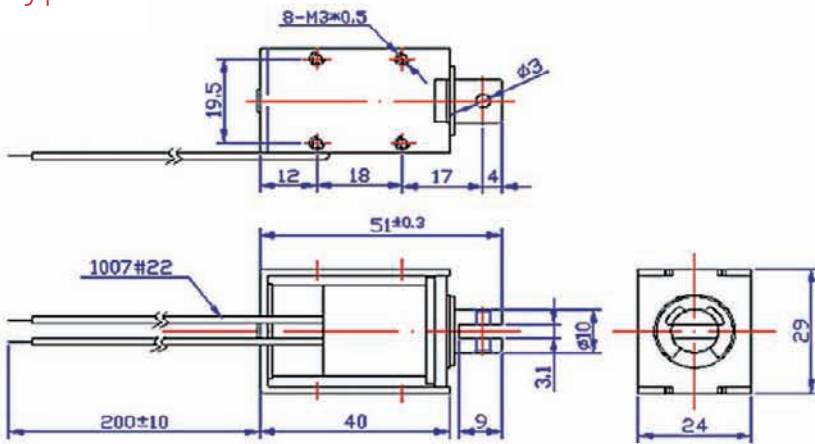

Force-stroke-diagram (N/mm)

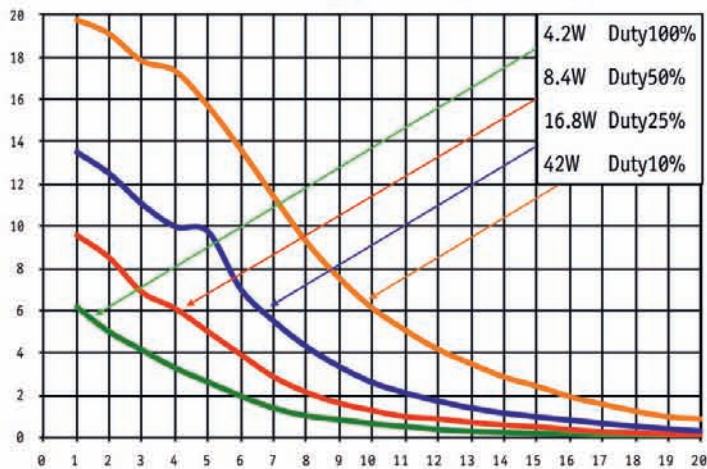

Description

Cheap and light-weight based on frame mode construction. Including damping ring and dumper inside the case. Open framed solenoid with closed brace.

Small but with overload passably stroke at the 12-20 mm.

Weight: 147 g

Coil Data

Relative Duty Cycle (%)	100	50	25	10
Max. Performance (Watt)	4,2	8,4	16,8	42
Max. Duty Cycle (sec.)	∞	100	36	7

Solenoid Model

Version:

Pull magnet

Pressure Solenoid with spring return

Current:

12 VDC (standard)

24 VDC (standard)

Please ask for other options.

Special Development On Request

Please contact us for your custom designed part (frame, force, special application, etc.)



SHENG TENG GmbH
 VAT-ID: DE 271 696 661
 General Manager:
 Silvio Bruske / Frank Loeffler
 District Court Munich reg. # HRB185777

Angerbrunnenstraße 11
 D-85356 Freising
 GERMANY

Phone: +49-8161-986 44 84
 Fax: +49-8161-986 44 74
 eMail: office@shengteng.de

www.shengteng.de